

**Câu 1: (2,0 điểm)**

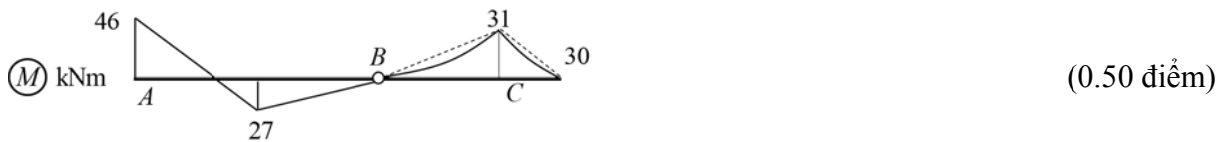

**Câu 2: (3,0 điểm)**

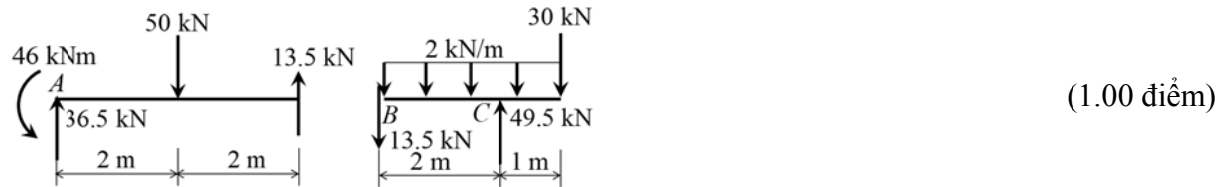
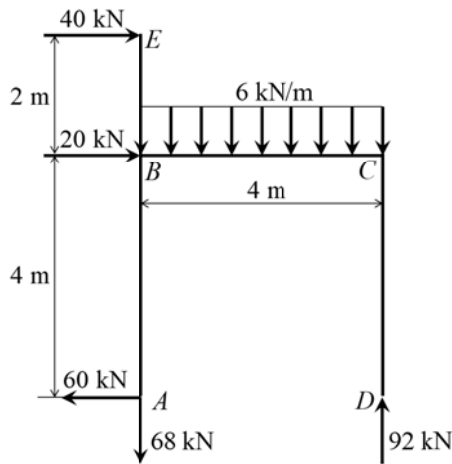

(1.50 điểm)

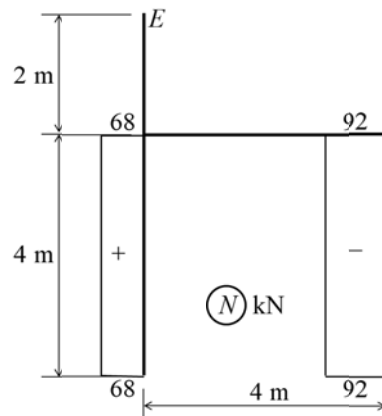

(0.50 điểm)

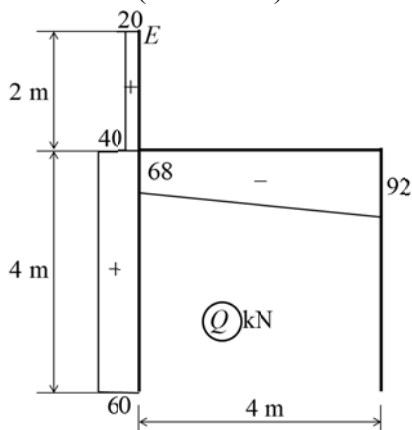

(0.50 điểm)

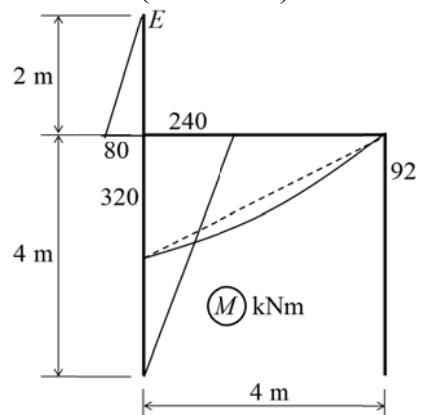

(0.50 điểm)

**Câu 3:** (1,5 điểm)

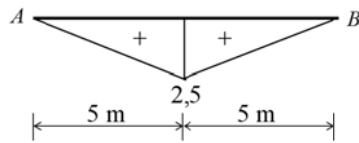

Đ.a.h. mô-men giữa nhịp (0.50 điểm)  
 Mô-men dương lớn nhất giữa nhịp:  
 1270 kNm (0.25 điểm)

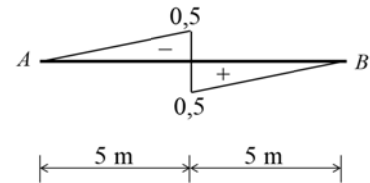

Đ.a.h. lực cắt giữa nhịp (0.50 điểm)  
 Giá trị tuyệt đối lực cắt lớn nhất giữa nhịp:  
 149 kN (0.25 điểm)

**Câu 4:** (3,5 điểm)

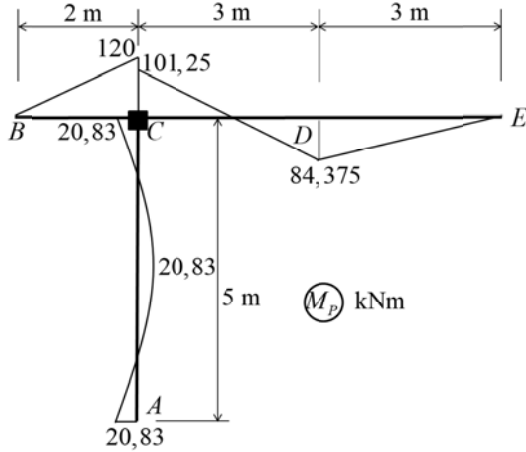

(0.75 điểm)  
 $R_{1p} = 39,58 \text{ kNm}$  (0.25 điểm)

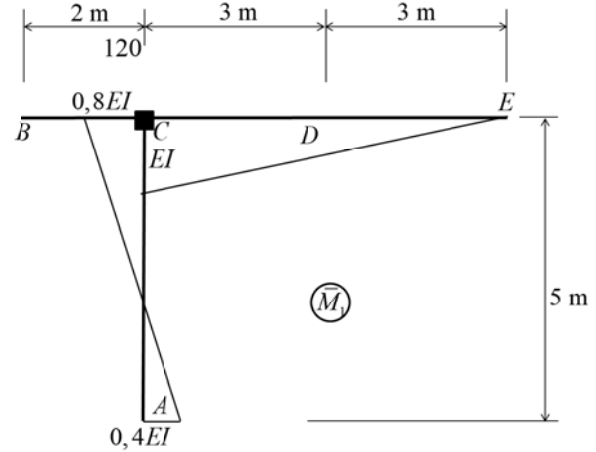

(0.75 điểm)  
 $r_{11} = 1,8EI$  (0.25 điểm)

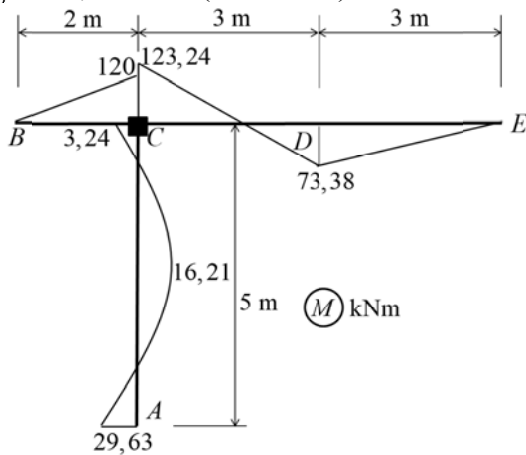

(0.50 điểm)

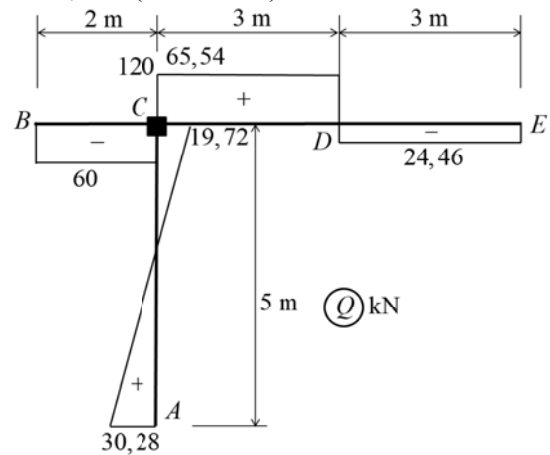

(0.50 điểm)

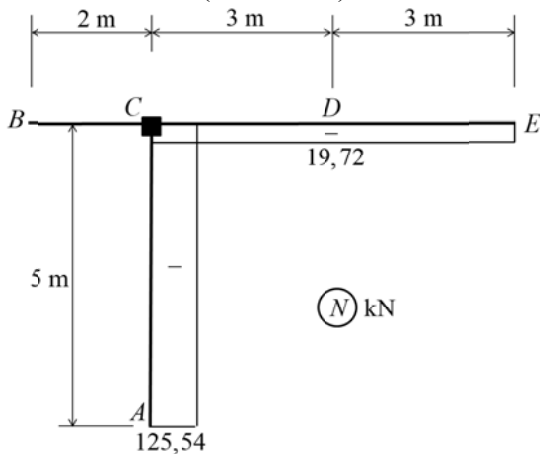

(0.50 điểm)